

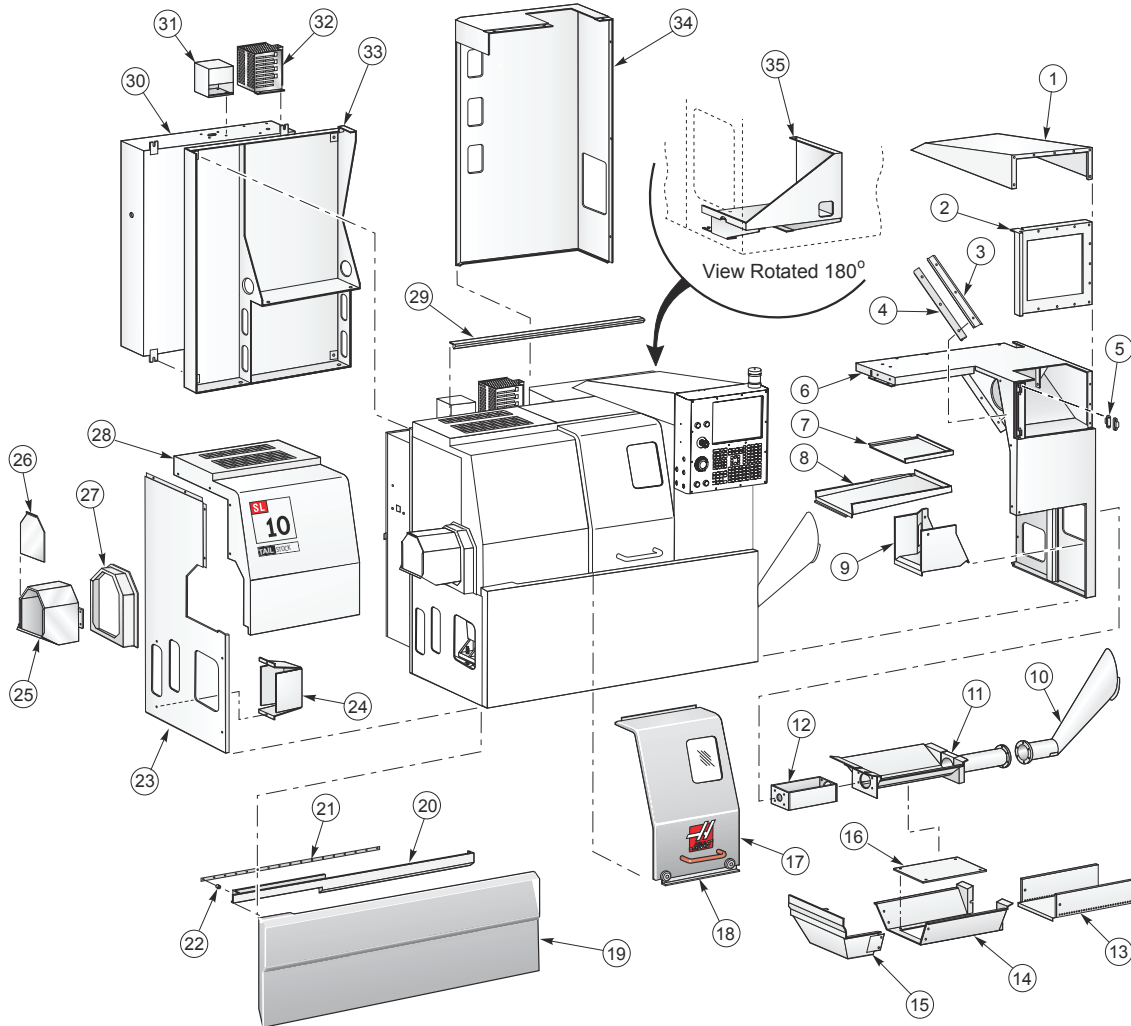

SL-10 - External Enclosure



- | | |
|---------------------------------------|-----------------------------------|
| 1. Monitor Cover | 19. Front Skirt |
| 2. Pendant Back Cover | 20. Lower Door Rail |
| 3. Z-Axis Right Bottom Wiper Retainer | 21. Door V-Track |
| 4. Z-Axis Right Bottom Wiper Felt | 22. Door V-Track Spacer |
| 5. R-Type Hinge Half | 23. Bottom Left Side Panel |
| 6. Right Panel | 24. Tramp Lube Oil Bottle Panel |
| 7. Tailstock Pan | 25. Coolant Collector |
| 8. NOTS Tray | 26. Coolant Collector Door |
| 9. Motor Pump Coolant Tray | 27. Coolant Collector Enclosure |
| 10. Discharge Chute | 28. Top Left End Panel |
| 11. Auger Pan Weldment | 29. Upper Door Rail |
| 12. Auger Mount | 30. Main Electrical Control Box |
| 13. Chip Tray Extension | 31. Cable Exit Cover |
| 14. Chip Tray Right | 32. Regen Assembly |
| 15. Chip Tray Left | 33. Control Box Bracket |
| 16. Chip Tray Bottom | 34. Rear Panel |
| 17. Door (Window) | 35. Hydraulic Pump Mount Weldment |
| 18. Door Inner Liner | |