



VMC - Side-Mount Tool Changer (SMTC) - Carousel Motor - Replacement

Scan code to get
the latest version
of this document



Translation
Available



VMC - Side-Mount Tool Changer - Carousel Motor - Replacement

Prerequisites

This procedure applies to several kits. You need only (1) of the motors listed under Parts Included to complete this procedure.

Machine Compatibility

Do this procedure on a vertical mill that has a side-mount tool changer.

Parts Included



93-30-2111 QTY: 1
MOTOR, SMTC CAROUSEL 40T



93-1642 QTY: 1
MOTOR, SMTC CAROUSEL 30/40T



93-1664 QTY: 1
MOTOR, SMTC CAROUSEL 50T

STEP 1

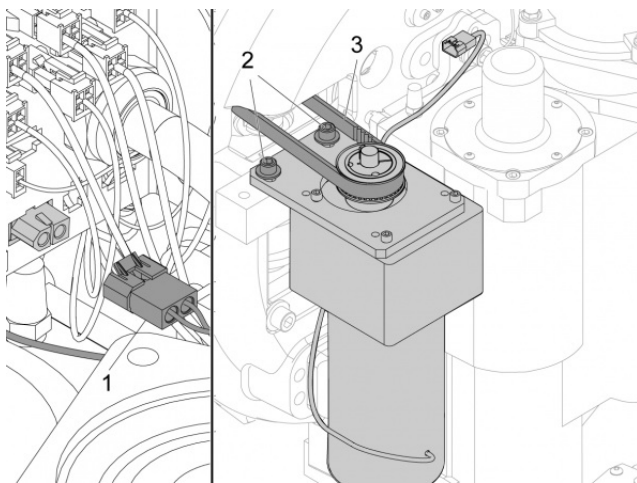

Remove the carousel cover assembly.

Disconnect the motor cable [1] from the electrical connector bracket.

Remove the (2) motor mount screws [2], the belt [3], and the used motor.

Install the new motor with the (2) motor mount screws [2].

Tighten the screws, but leave them loose enough to control the adjustment of the belt.

Put the new belt around the tool changer sprocket and the motor sprocket.

Tighten the belt until it has no more than 1/8 inch (3 mm) of deflection.

Torque the motor mount place screws [2] to 15 ft-lb (20.34 Nm).

Connect the motor cable [1] at the electrical connector bracket.

Replace the carousel cover assembly.